

# HB20MOBX5UK

Hisense

Microwave oven, 20 l, 800 W, Touch control, Black

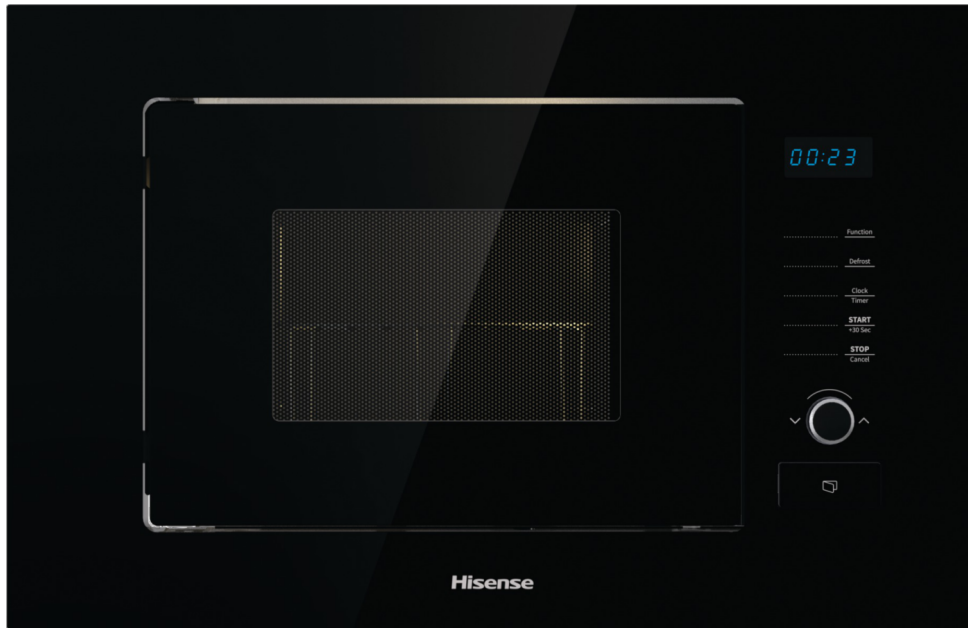

Multiphase  
Cooking



Defrost Function



Easy Clean

## General information

Product group:	<b>Microwave oven</b>	Colour of the product:	<b>Black</b>
Interior material:	<b>Stainless steel</b>	Control panel material:	<b>Glass</b>
Door open type:	<b>Button</b>		

## Efficiency

Oven volume:	<b>20 L</b>	Number of power levels:	<b>5</b>
Preinstalled programmes:	<b>8</b>	Microwave power:	<b>800 W</b>
Plate diameter:	<b>245 mm</b>		

## Control

Input type:	<b>Touch control</b>	Control type:	<b>Electronic</b>
Time display:	<b>Yes</b>		

## Heating types

Combined heating:	<b>Microwaves</b>	Type of microwave distribution:	<b>Rotating plate</b>
Technology of producing microwaves:	<b>Standard technology (HTV)</b>		

## Features

Multi level cooking:	<b>Yes</b>	AUTO menu:	<b>Yes</b>
Smart Control:	<b>No</b>	Speed and auto defrost (by time and weight):	<b>Quick &amp; automatic (per time &amp; weight)</b>
Sound signal:	<b>Yes, no possibility to turn off</b>		

## Equipment

Rotating plate:	<b>Glass</b>
-----------------	--------------

## Safety

ChildLock:	<b>Control panel lock</b>
------------	---------------------------

## Technical data

Noise level (max):	<b>63 dB(A)</b>	Consumption in standby mode:	<b>1 W</b>
Width of the product:	<b>594 mm</b>	Height of the product:	<b>382 mm</b>
Depth of the product:	<b>335 mm</b>	Width of internal space:	<b>295 mm</b>

Height of internal space:	<b>218 mm</b>	Depth of internal space:	<b>314 mm</b>
Width of niche size for installation max.:	<b>568 mm</b>	Width of niche size for installation min.:	<b>560 mm</b>
Height of niche size for installation max.:	<b>362 mm</b>	Height of niche size for installation min.:	<b>362 mm</b>
Depth of niche size for installation min.:	<b>340 mm</b>	Width of the packed product:	<b>663 mm</b>
Height of the packed product:	<b>445 mm</b>	Depth of the packed product:	<b>407 mm</b>
Gross weight:	<b>15.6 kg</b>	Net weight:	<b>14 kg</b>
Voltage:	<b>230 V</b>	Frequency:	<b>50 Hz</b>
Product code:	<b>738283</b>	EAN code:	<b>3838782495861</b>

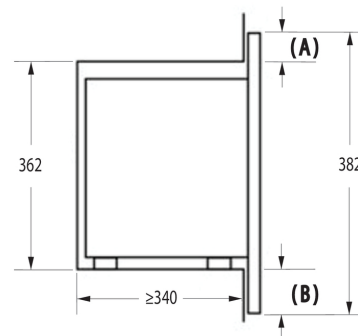
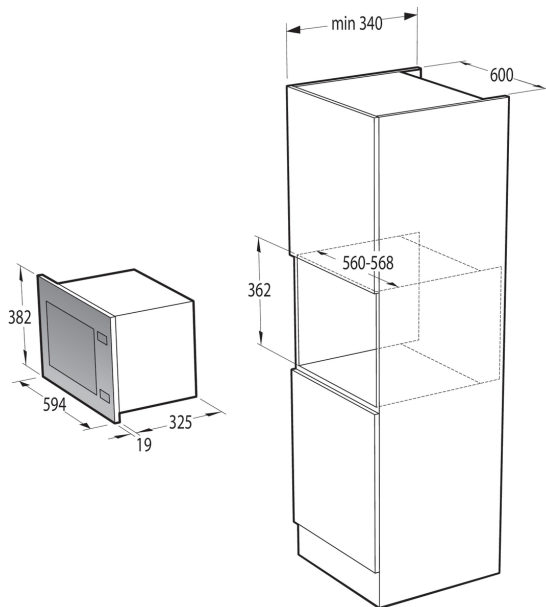

Installation of a microwave oven and frame overhangs: \*All dimensions in mm  
**A:** Frame overhang above Niche height 362: 7 mm  
**B:** Frame overhang below Niche height 362: 13 mm