



# SERVICE PARTS LIST

**BULLETIN NO.**  
**54-22-2405**

SPECIFY CATALOG NO. AND SERIAL NO. WHEN ORDERING PARTS		REVISED BULLETIN	DATE
<b>M12 FUEL MULTI-TOOL</b>			Aug. 2020
<b>CATALOG NO.</b>	<b>2526-20</b>	<b>WIRING INSTRUCTION</b>	
<b>STARTING SERIAL NO.</b>	<b>L31A</b>	<b>See Page 3</b>	

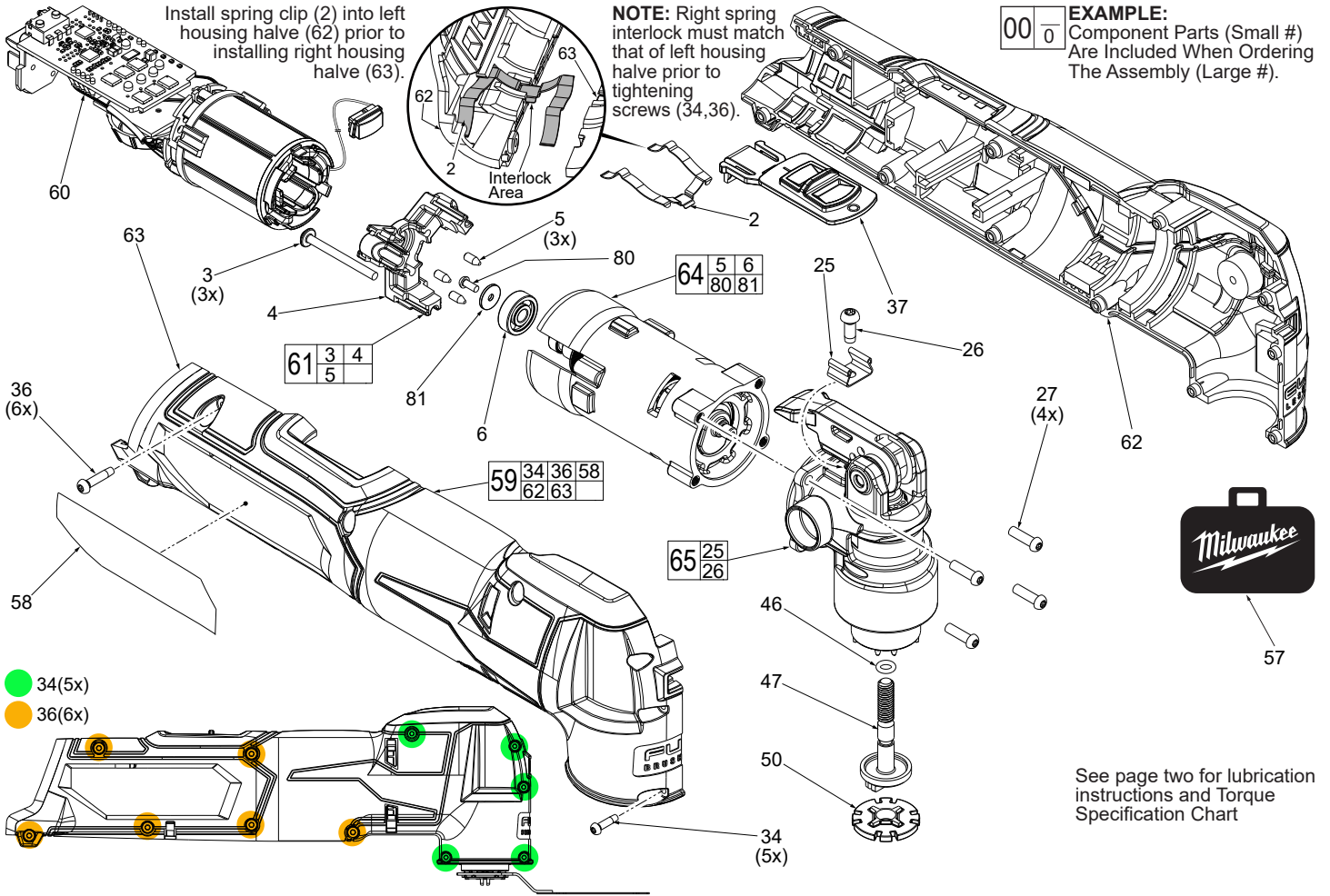
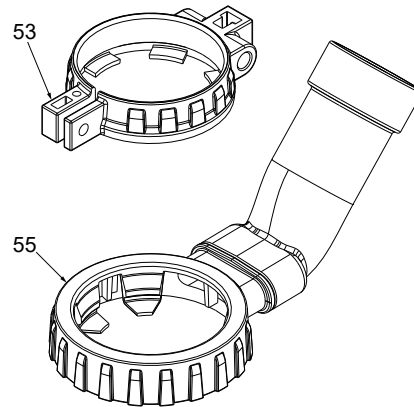

FIG.	PART NO.	DESCRIPTION OF PART	NO. REQ.
	2	42-70-0480 Spring Clip	(1)
	3	----- M3 x 35mm PWH T-10 Machine Screw	(3)
	4	----- Motor End Plate	(1)
	5	45-30-0047 Rubber Slug	(3)
	6	02-04-0568 Ball Bearing	(1)
	25	42-70-0510 Quick Release Clip	(1)
	26	05-78-0105 M4 x 10mm Pan Hd. Taprite T-20 Screw	(1)
	27	05-78-1010 M3.5 x 12mm Pan Hd. T-10 Machine Screw	(4)
	34	06-82-2395 M2.6 x 10mm Pan Hd. ST T-8 Screw	(5)
	36	06-82-1080 M3 x 14mm Pan Hd. ST T-10 Screw	(6)
	37	45-72-0140 Switch Slide	(1)
	46	34-40-0431 O-Ring	(1)
	47	06-75-1015 Blade Fastener	(1)
	50	48-03-2526 Adapter (Accessory-Sold Separately)	(1)
	53	49-90-2430 Depth Stop (Accessory-Sold Separately)	(1)
	55	49-90-2420 Dust Extractor (Accessory-Sold Separately)	(1)
	57	42-55-2526 Lunchbox Contractor Bag	(1)
	58	12-20-2531 Service Nameplate	(1)
	59	31-44-2003 Housing Kit	(1)
	60	14-20-2526 Electronics Assembly	(1)
	61	14-46-2526 Motor End Plate Kit	(1)
	62	----- Left Housing Kit with Cushions	(1)
	63	----- Right Housing Kit with Cushions	(1)
	64	14-50-2526 Motor Assembly	(1)
	65	14-29-2526 Gearcase Assembly	(1)
	80	05-88-1015 M2.5 x 6mm Pan Hd. Phillips Mach. Screw	(1)
	81	45-88-0201 Flat Washer	(1)



**LUBRICATION:**

- = Type 'J' Grease (1 lb. can), 49-08-4220
- = 277 Red Loctite,® 44-22-0050

- ① = Fill back cavity of Gearcase (65) with approx. 3.5 grams of grease.
- ② = Place a few drops of thread locking sealant to threads of motor end plate screws (3).
- ③ = Place a few drops of thread locking sealant to threads of rear armature screw (80).
- ④ = Place a few drops of thread locking sealant to threads of gearcase screws (27).

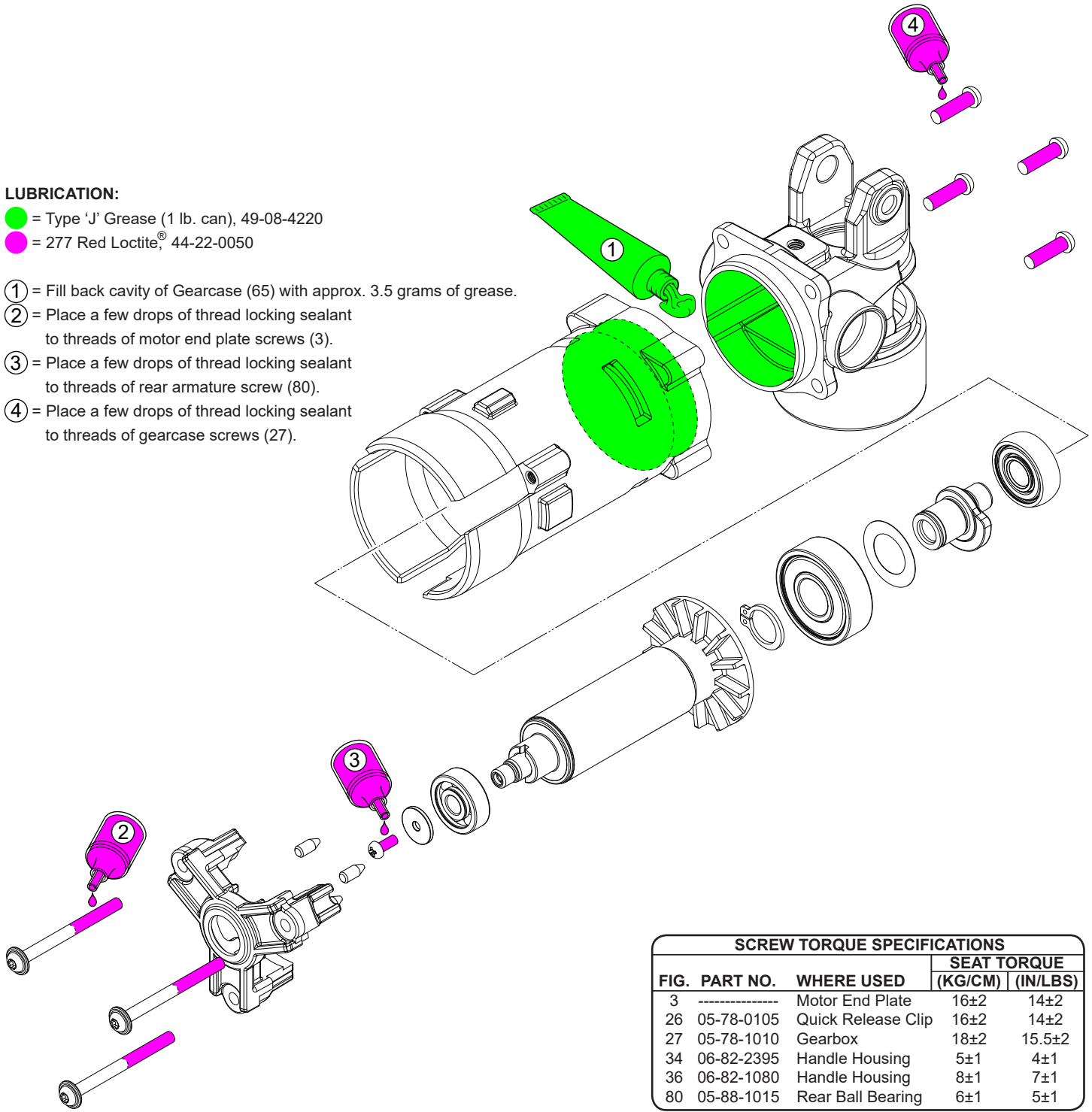

SCREW TORQUE SPECIFICATIONS				
FIG.	PART NO.	WHERE USED	SEAT TORQUE	
			(KG/CM)	(IN/LBS)
3	-----	Motor End Plate	16±2	14±2
26	05-78-0105	Quick Release Clip	16±2	14±2
27	05-78-1010	Gearbox	18±2	15.5±2
34	06-82-2395	Handle Housing	5±1	4±1
36	06-82-1080	Handle Housing	8±1	7±1
80	05-88-1015	Rear Ball Bearing	6±1	5±1

AS AN AID TO REASSEMBLY, TAKE NOTICE OF WIRE ROUTING AND POSITION IN WIRE GUIDES AND TRAPS WHILE DISMANTLING TOOL.

BE SURE THAT ALL COMPONENTS OF THE ELECTRONICS KIT ARE SEATED FIRMLY AND SQUARELY IN THE HANDLE RECESSES.

AVOID PINCHED WIRES, BE SURE THAT ALL WIRES AND SLEEVES ARE PRESSED COMPLETELY DOWN IN WIRE GUIDES AND TRAPS.

PRIOR TO SECURING THE HANDLE COVER ONTO THE HANDLE SUPPORT, BE SURE THAT THERE ARE NO INTERFERENCES.

BEFORE INSTALLING THE BATTERY, CHECK FOR PROPER FUNCTIONALITY OF SHUTTLE AND TRIGGERS.

INSTALL BATTERY AND DEPRESS SWITCH TRIGGER TO ASSURE TOOL IS OPERATING PROPERLY.

