

the Kitchen Wizz™ 11 Plus

Instruction Book - BFP680



Breville®



Contents

2	Breville Recommends Safety First
6	Components
9	Assembly
10	Functions
16	Food Processing Guide
18	Care & Cleaning
19	Troubleshooting
21	Recipes

IMPORTANT SAFEGUARDS

At Breville we are very safety conscious. We design and manufacture consumer products with the safety of you, our valued customer, foremost in mind. In addition we ask that you exercise a degree of care when using any electrical appliance and adhere to the following precautions.

BREVILLE RECOMMENDS SAFETY FIRST

- Carefully read all instructions before operating the food processor for the first time and save for future reference.
- Remove any packaging material and promotional labels before using the food processor for the first time.
- Do not place the food processor near the edge of a bench or table during operation. Ensure the surface is level, clean and free of water, flour, etc. Vibration during operation may cause the appliance to move.
- Handle the food processor and attachments with care - remember the blades and discs are razor-sharp and should be kept out of reach of children.
- Care shall be taken when handling the sharp cutting blades, emptying the bowl and during cleaning.
- Always make sure the food processor is completely assembled before operating. The appliance will not operate unless properly assembled.
- Ensure the OFF button has been pressed, and the food processor is switched off at the power outlet and unplugged before attaching the quad blade, dough blade, disc or processing lid.
- Always secure the processing bowl onto the motor base before attaching the quad blade, dough blade or discs.
- Always operate the food processor with the processing lid securely in position.

- Do not push food into the feed chute with your fingers or other utensils. Always use the food pusher provided.
- Keep hands, knives and other utensils away from moving quad blade, dough blade or discs.
- Do not place hands or fingers in the bowl of the food processor unless the motor, quad blade, dough blade or discs have come to a complete stop.
- Ensure the OFF button has been pressed to switch the motor off and the appliance is switched off at the power outlet and unplugged before removing the lid from the bowl.
- Do not use attachments other than those provided with the food processor.
- Do not attempt to operate the food processor by any method other than those described in this booklet.
- Ensure the motor, blades or discs have completely stopped before disassembling. Ensure the OFF button has been pressed and the appliance is switched off at the power outlet and unplugged when not in use, if left unattended and before disassembling, cleaning or storing.
- Care should be taken when removing the food from the processing bowl by ensuring the motor, quad blade, dough blade or disc, have completely stopped before disassembling. Ensure the OFF button has been pressed to switch the motor off; the appliance is switched off at the power outlet and unplugged, before removing the lid from the bowl. The processing bowl should then be unlocked from the motor body and the quad blade, dough blade or discs carefully removed before attempting to remove the processed food.
- Please do not crush ICE in the large or small processing bowls. This will cause damage to the blades (quad or mini blade). We recommend that you use a blender for ice crushing.
- Some stiff mixtures, such as dough may cause the processing blade to rotate more slowly than normal. If this happens, do not process for longer than 1 minute.
- Do not process hot or boiling liquids - allow liquids to cool before placing into the processing bowl.

- Do not use the food processor on slippery, unstable or uneven surfaces such as a sink drain board.
- To protect against electric shock do not immerse power cord, plug or motor base in water or any other liquid.
- Do not move the food processor whilst in operation.
- Do not leave the food processor unattended when in use.
- Do not place any part of the food processor in the microwave oven.
- Do not fill bowl above marked liquid levels or 11 cup dry level (shredding). Always add drier or thicker ingredients to the processing bowl prior to adding fluids.
- Never remove the lid while the processor is operating. Always use the POWER/OFF button to stop the machine before removing the lid.
- Keep the appliance clean. Follow the cleaning instructions provided in this book.

IMPORTANT SAFEGUARDS FOR ALL ELECTRICAL APPLIANCES

- Unwind the power cord fully before use.
- Do not let the power cord hang over the edge of a table, counter, touch hot surfaces or become knotted.
- Cleaning and user maintenance shall not be made by children without supervision.
- This appliance shall not be used by children. Keep the appliance and its cord out of reach of children.
- Children shall not play with the appliance.
- Appliances can be used by persons with reduced physical, sensory or mental capabilities or lack of experience and knowledge if they have been given supervision or instruction concerning use of the appliance in a safe way and understand the hazards involved.
- It is recommended to regularly inspect the appliance. Do not use the appliance if power supply cord, plug or appliance becomes damaged in any way. Return the entire appliance to

the nearest authorised Breville Service Centre for examination and/or repair.

- This appliance is for household use only. Do not use this appliance for anything other than its intended use. Do not use in moving vehicles or boats. Do not use outdoors.
- The installation of a residual current device (safety switch) is recommended to provide additional safety protection when using electrical appliances. It is advisable that a safety switch with a rated residual operating current not exceeding 30mA be installed in the electrical circuit supplying the appliance. See your electrician for professional advice.
- All maintenance (other than cleaning) is to be done by an authorised Breville Service Centre.
- Authorised Breville Service Centres can be found on our website www.Breville.com.au Alternatively, you can contact the Breville Customer Care Centre by phone on **1300 273 845** or email AskUs@breville.com.au



WARNING

- To avoid possible malfunction of the processing bowl's auto switch, do not place the processing lid in the locked position when the appliance is not in use.
- The processing blades and discs are extremely sharp, handle with care at all times. Do not place hands, knives or other utensils into the feed chute. Always use the food pusher to push the food down the feed chute.

SAVE THESE INSTRUCTIONS

SPECIFICATION

Power Rating	220-240V-50Hz 1000W
Outside Dimensions	440mm (H) with bowl 195mm (W) 280mm (D)
Net Weight	Approx. 7.5kg

These specifications may change without notice.



Components

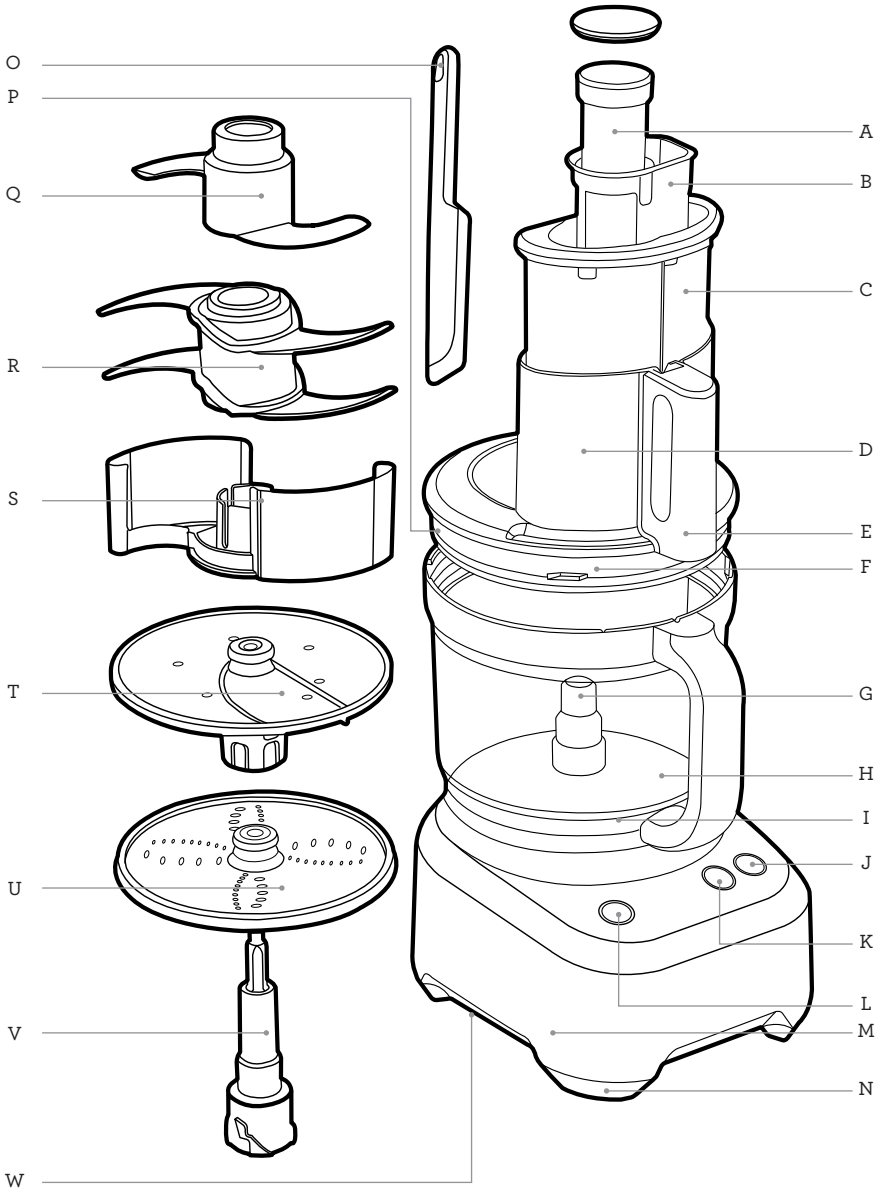

A. Small food pusher

Remove to process smaller ingredients with improved control. It also doubles as a measuring cup for ingredients. Note that the food processor will run continually whether the small pusher is in or out.

B. Mid food pusher

The food processor will run continually whether the mid pusher is in or out.

C. Large food pusher

Note that the food processor will not start unless the large pusher is in place correctly, as it releases the safety interlock system.

D. Extra wide feed chute

13cm wide, for large ingredients.

E. Safety interlock system

Prevents the motor from operating unless the bowl and lid are correctly locked in position, and large feed pusher is inserted.

F. Processing lid

Locks onto the processing bowl and forms part of the safety interlock system.

G. Bowl coupling

Sintered stainless steel motor connector with vibration absorption.

H. Processing bowl

1l cup capacity for dry ingredients and 8 cups for thick liquid ingredients (eg. soups). The processing bowl locks onto the motor base by turning clockwise.

I. Safety braking system

Rapidly stops Quad® blade if lid is unexpectedly opened.

J. PULSE button

Press and release for momentary bursts of power.

K. START | PAUSE button

Once the POWER button has been activated, this will start and stop the motor.

L. POWER | OFF button

Provides power to the food processor unit, and puts it into READY mode.

M. Direct drive motor base

Induction motor for high torque and reliable results.

N. No-skid rubber feet

O. Plastic spatula

For scraping the sides of the bowl helping to process ingredients evenly

P. Silicone seal

This replaceable seal reduces the chance of leakage while processing larger volumes of liquid ingredients.

Q. Dough blade

Blunt blade designed for a softer action of combining dough ingredients.

R. Quad® blade

Swift action for even chopping, mixing, whipping and processing a variety of ingredients. Safety braking system rapidly stops Quad® blades if lid is unexpectedly opened.

S. Quad® blade cover

T. Adjustable slicer 0.3mm-8.0mm thickness

U. Fine and coarse reversible shredder

V. Spindle

Use with all blades and discs.

W. Cord Storage

Cord can be pushed into the housing to reduce length.

BREVILLE ASSIST™ PLUG

Your Breville appliance comes with a unique Breville Assist™ Plug, conveniently designed with a finger hole to easy removal from the wall outlet.

Plastic spatula

Fine and coarse
reversible shredder

Adjustable slicer

Quad® blade

Dough Blade

Storage case

Spindle

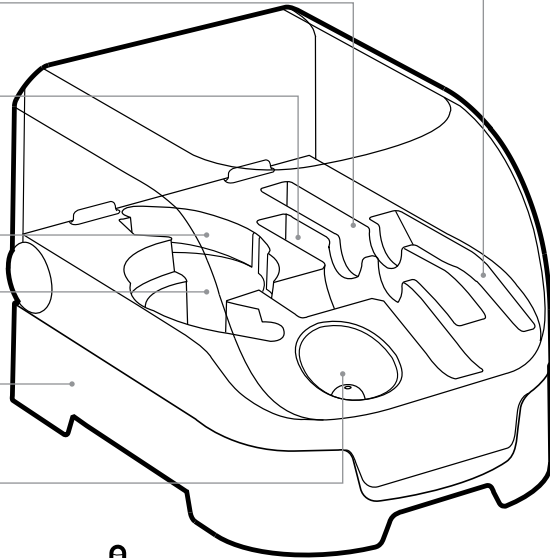

X

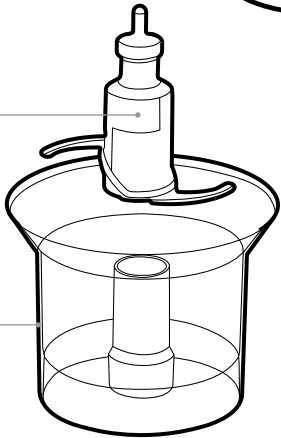

Y

Storage case

Store all discs and blades safely when not in use.

X. Mini processing blade

Used for chopping, mixing, and blending a variety of ingredients.

Y. Mini processing bowl

For processing small volumes of ingredients.



Assembly

BEFORE FIRST USE

- Before using your food processor for the first time, remove any packaging material and promotional labels. Ensure the POWER button is OFF and the food processor is unplugged.
- Be careful when handling the blades and discs as they are extremely sharp.
- Wash the processing bowl, processing lid and all attachments in warm soapy water with a soft cloth. Rinse and dry thoroughly. The attachments may be washed in the dishwasher.
- When first using your food processor, you may notice an odour coming from the motor. This is normal and will dissipate with use.
- Always use the food processor on a dry, level work surface.

ASSEMBLY

1. Position the processing bowl onto the motor base with the handle in line with the ALIGN HANDLE graphic on the motor base.



2. Turn the bowl clockwise until the handle locks to the front. The processing bowl should now be securely locked into position. The food processor will not operate unless the bowl is locked into position correctly.



3. The spindle is required when using ALL discs and blades EXCEPT the mini bowl and mini blade. Failing to use the spindle will damage the parts, and incorrect use this way may cause the parts to fuse together.



4. Before placing the lid onto the processing bowl, position the spindle over the coupling in the center of the processing bowl. Then position your chosen blade or disc over it. The blades drop down lower than the discs.



5. Place lid onto the processing bowl so that the **ALIGN | LOCK** graphics on the lid and handle align. To **LOCK** the lid, hold the chute and turn clockwise so that the handle parts align. Locking the lid correctly will engage the interlocking safety catch on the handle, and allow the motor to run.



MINI PROCESSING BOWL

- The mini processing bowl fits inside the main bowl.



- The mini processing blades give you maximum control for small quantities.
- Do not use the spindle, or the processing discs.
- The mini blades cannot be used in the main processing bowl.



Functions

OPERATION

- The food processor will only operate when the processing bowl, lid and large pusher are correctly assembled. This engages the safety interlock, and allows the motor to run.
- The **POWER | OFF** button illuminates red when the machine is connected to power and is ready to run.
- The **START | PAUSE** button allows the motor to run continuously until pressed again. If the lid, bowl or large pusher are removed while the motor is running, the button will flash. The motor will resume running when the bowl, lid and large pusher are assembled and the safety interlock is engaged, the button light will be solid (no longer flashing).
- The momentary **PULSE** button is ideal for processing foods that need sudden bursts of power. It also encourages ingredients to move around the bowl. **PULSE** is also best when processing foods that only require processing for a short period of time.
- Use a combination of the **START | PAUSE** and **PULSE** buttons for control when processing food.
- The chute has a **MAX CHUTE FILL** graphic to indicate the maximum volume of food that can be placed in the chute for the pusher to activate the safety locking catch.
- After processing, wait until the blades/discs have stopped moving before unlocking the lid. To ensure safe handling, turn off at the **POWER** button and unplug at the power outlet before handling the blades.
- When removing blades/discs, lift by carefully grip the plastic hub in the centre.

OVERLOAD PROTECTION SYSTEM

- The food processor has an overload protection system to prevent damage to the motor. If activated, the food processor will go into STANDBY mode, and the buttons will flash.
- Unplug and allow to cool for 30 minutes. Once cooled, you will be able to use the food processor as usual again.
- Note that some stiff mixtures (such as bread dough) may cause the blade to rotate more slowly than normal. If this happens, do not process for more than 1 minute.
- If the blades or discs jam with food while processing, immediately unplug from the power outlet before clearing the wedged food. If this happens more than once, the bowl may be overloaded. Try processing in smaller batches.

CHOPPING WITH THE QUAD® BLADE

The micro-serrated Quad® blade chops raw and cooked food to the consistency required, from coarsely chopped to minced. The blades process very efficiently, and may take less time than expected to process many large tasks.

Always remember to place the spindle and Quad® blade into the processing bowl before adding the food.

Avoid over-processing by checking the consistency frequently. For many tasks, we recommend using the PULSE button, as it may only take a few seconds to fully process food to your desired consistency.

If necessary, turn the POWER off and use a spatula to scrape down the sides of the bowl to encourage even processing.

Raw vegetables, fruit and cooked meats

Trim and cut food into 2.5cm cubes. Process no more than 5½ cups at a time using the PULSE button at 1-2 second intervals until chopped to desired size or consistency.

Raw meat, chicken and fish

Trim excess fat and cut food into 2.5cm cubes. Ensure all bones are removed. Chill well in freezer until firm as this will help to cut through the food more readily. Process no more than 800g of raw meat at a time. At this capacity the motor should run for no more than 30 seconds at a time. Use a combination of the START | PAUSE and the PULSE button until chopped or minced to the desired consistency.

Garlic, chili and ginger

Peel garlic cloves and process them whole. Leave chilies whole, or remove seeds for milder chili. Peel and cut ginger into 2.5cm cubes.

For other solid herbs like lemongrass or galangal, peel and cut into cubes or pieces between 1 and 2cm in size.

Size should be made smaller for harder or more dense herbs.

Process using the PULSE button at 1-2 second intervals until chopped to the desired consistency.

If adding garlic, chili or ginger to other ingredients, drop whole pieces down the small feed chute while the motor is running.

Leafy herbs

Wash and dry herbs thoroughly. Remove any coarse stems. Process no more than 2 bunches of herbs (approx. 4 cups) at a time using the PULSE button at 1-2 second intervals until chopped to the desired consistency.

Use leafy herbs immediately for the most aromatic results in your recipe.

Nuts

Process no more than 4 cups of shelled nuts at a time using the PULSE button at 1-2 second intervals until chopped to the desired consistency.

Dried fruit

Dried fruit can be sticky, and may stick to the blades during processing. We recommend putting dried fruit in the freezer for about 10 minutes before processing. Process no more than 2 cups at a time using the PULSE button at 1-2 second intervals until chopped to the desired consistency.

If chopping fruit to add to cake mixture, process the fruit before making the cake mix. Add a little flour (from the quantity of flour in the recipe) to prevent fruit from sticking to the Quad® blade.

We do not recommend chopping large dried fruits such as dates and figs.

Soft breadcrumbs

Break stale bread into chunks (fresh bread will stick to blades). Process no more than 4-6 slices at a time using the PULSE button at 1-2 second intervals until crumbed to desired consistency. For best results when making bread crumbs, add one slice at a time.

Dried breadcrumbs

Tear bread into chunks and toast in oven until golden and crisp. Do not over brown. Process no more than 4-6 slices at a time using the PULSE button at 1-2 second intervals.

Biscuit crumbs

Break biscuits into quarters, and weigh a maximum of 250g. Process using the PULSE button at 1-2 second intervals until chopped to the desired consistency. Sweet or savoury biscuit crumbs can be used as an alternative to pastry for sweet or savoury pies.

Do not process very hard biscuits as this may damage the blades.

PURÉEING WITH THE QUAD® BLADE

The micro-serrated Quad® blade purées raw and cooked food to the consistency required, including baby food. The blades process very efficiently, and cut the time needed to purée many tasks.

Always remember to place the Quad® blade into the processing bowl before adding the food.

Carefully remove the Quad® blade after puréeing food and use a spatula to scrape food adhering to the blade and bowl.

Baby food

Trim and cut vegetables and meat into 2.5cm cubes. Cook vegetables and meat before processing. Process no more than 5½ cups at a time using the START | PAUSE button in intervals until the food is puréed to a smooth and even consistency. Stock, milk or gravy can be added through the small feed chute if the mixture becomes too thick.

Excess baby food can be frozen in ice-cube trays, and packed in single serve freezer bags ready for use.

Peanut butter

Process no more than 4 cups of shelled nuts at a time using the START | PAUSE button until chopped to the desired consistency.

The volume of nuts reduces after processing, for example 2 cups of nuts will make around 1 cup of nut butter.

Natural nut butter (without using stabilizers) will separate on standing, and needs to be stirred before use.

MIXING WITH THE QUAD® BLADE

The Quad® blade mixes ingredients for cakes, batters, and cookie doughs.

The Quad® blade can also emulsify egg-based sauces such as mayonnaise.

Always remember to place the spindle and Quad® blade into the processing bowl before adding the food.

Butter cake and biscuit dough

Place softened, chopped butter and sugar into the processing bowl. Process using the START | PAUSE button until the mixture is lightly creamed. With the motor running, add eggs one at a time through the small feed chute, mixing well after each egg is added. Take lid off and add liquid and dry ingredients to the mixture. Process using the PULSE button until folded evenly. Scrape down sides of bowl as needed. Do not over-process.

Add choc chips, nuts, dried fruit, etc after the main mixture is done. Use the PULSE button in very short bursts until the additions are combined. Do not over-process, as these larger ingredients will break down quickly.

Quick-mix cakes and batters

Place all ingredients in the bowl, starting with liquids, and being careful not to exceed the MAX LIQUID level. Process using the PULSE button until folded evenly. Scrape down sides of bowl as needed. Do not over-process.

This method can also be used for melt 'n' mix cakes, packet cake mixes and crêpe batters.

Pastry dough

Place flour and chilled, cubed butter into the processing bowl.

Do not process more than 2 cups (300g) of flour using the START | PAUSE button in intervals until the butter is absorbed into the flour.

Steadily add liquid through the small feed chute with the motor still running. Process until the mixture forms a ball.

KNEADING WITH THE DOUGH BLADE

Always remember to place the spindle and dough blade into the processing bowl before adding the food.

The edges of the plastic dough blade create a softer action for combining dough ingredients. The dough blade encourages the gluten strands to be stretched rather than cut, and should be used for all yeast doughs, and any other doughs that require kneading.

Bread or pizza dough

Place flour and dry ingredients into the processing bowl, including instant active dry yeast.

Do not process more than 4²/₃ cups (700g) of flour or using the START | PAUSE button in intervals.

Steadily add liquid (including oil, if applicable) through the small feed chute with the motor still running. Process until the mixture until it forms a soft, elastic dough ball.

Transfer dough ball to a lightly floured surface and knead for a further 5 minutes if necessary until soft and pliable.

If processing more than two recipes of dough ingredients (700g flour), allow the motor base to cool for an extended period before subsequent kneading to prevent the motor from overloading.

Place dough into a large, greased mixing bowl and cover. Stand in a warm place until it has doubled in size. Turn the dough out onto a lightly floured surface and knead again until smooth and elastic. Shape the dough then allow to rise in a warm area before baking in a hot oven.

SLICING, GRATING AND SHREDDING

Important: The spindle must be used with both the adjustable slicer and the reversible shredder/grater.

Adjustable slicer

The adjustable slicer will slice food to an even and consistent thickness. It can be adjusted to 24 settings, from very fine (0.3mm) to thick (8.0mm). To adjust the slicing thickness, hold the adjustable slicing disc by the outer edge with one hand, and turn the adjustment dial on the underside with the other hand. An arrow graphic indicates the thickness of the slice you have chosen.

Reversible grater and shredder

This disc has an array of small blades on both sides of the disc. Align the disc so larger holes face up for courser textured results, or with the smaller holes facing up for finer results. The discs are labelled showing which side faces up.

CONTROLLING THE INGREDIENTS

It is important to position the food in the chute to gain maximum control and best results.

Smaller ingredients

For long thin foods such as carrots, cucumbers, zucchini, etc., use the small feed chute. This will avoid the ingredient from tipping over during slicing.

Larger ingredients

The wide feed chute is 13cm wide, and can fit ingredients up to this size. The chute can be packed to fill the width of the chute. The food should fit snugly so it is supported in an upright position in the chute, but not so tight that it could prevent the food from moving down the chute.

Take care not to overfill the chute, as the pusher will not activate the interlock safety catch if the chute is too full. Do not fill over the MAX CHUTE FILL graphic.

Medium feed chute

Use the medium feed chute for 'in-between' food processing. The medium feed chute is 7cm wide, and can fit ingredients up to this size. The chute can be packed to fill the width of the chute. The food should fit snugly so it is supported in an upright position in the chute, but not so tight that it could prevent the food from moving down the chute.

Pressure

When processing, never force the food down the chute as this can damage the discs.

Apply light pressure for soft foods such as tomatoes and bananas.

Apply medium pressure for firmer foods such as potatoes and apples.

Apply firm pressure for hard foods such as parmesan cheese and deli meats such as salami.

Round fruit and vegetables

Prepare fruit or vegetables by washing and peeling (if necessary).

Small fruit and vegetables should be trimmed on one end so the food sits flat inside the feed chute.

Large fruit and vegetables may need to be cut in half to fit in the chute.

Long fruit and vegetables

Prepare fruit or vegetables by washing and peeling (if necessary).

Ingredients can be cut cross-sectionally to create circular results. Use the small and medium feed chute, or pack ingredients vertically in the large feed chute.

Ingredients can be cut lengthwise to create ribbons. Use the large feed chute, and trim ingredients if necessary to encourage them to sit flat in the feed chute when the disc starts. Pack the large feed chute horizontally.

Leafy vegetables

Cut cabbage into wedges to fit the feed chute. For lettuce, separate leaves, then roll up and pack vertically in the feed chute.

Cheese

Caution should be taken when processing cheese in a food processor. For soft cheese such as mozzarella, partially freeze it until firm. This will help prevent jamming the disc.

Round cheeses such as mozzarella should be trimmed at one end to encourage them to sit flat in the feed chute with the disc starts.

Hard cheeses such as parmesan must be checked first to ensure they are not too hard (to avoid damaging blade edges). The cheese should slice easily with a sharp knife and remove the rind before processing.

Wedge shaped cheeses such as parmesan can be packed side by side to form a rectangular shape in the chute.

Deli meats

Cut in lengths to fit the height of the feed chute. The length must not be higher than MAX CHUTE FILL graphic. Pack with the cut side facing down. For hard cured sausages like salami and pepperoni trim on one end and process one sausage at a time through the small or medium feed chute, depending on size.

Chocolate

Break a block of chocolate into small pieces, and chill until firm. Pack into the small feed chute, and then shred.

MINI BOWL AND BLADE

The mini processing bowl is used inside the main processing bowl. It is for better control when processing small quantities of food, or herb/spice mixes. It can be used for chopping, mixing and blending a variety of ingredients.

The mini blade can not be used inside the main processing bowl.

The main processing attachments will not fit inside the mini bowl.



Food Processing Guide

For more information about preparation of food and how to process, refer to basic processing techniques. For specific recipes, refer to the recipe section.

FOOD	BLADE TYPE	ADJUSTABLE SLICING DISC THICKNESS	RECOMMENDED DISC TYPE
Avocado	Quad® blade or mini Use: Guacamole	2-5	
Beetroot (cooked)		2-5	Shredder Use: Salad
Butternut Pumpkin	Quad® blade Use Butternut Pumpkin soup		
Cabbage / Lettuce		Thin 1-2 and med 2-3 Use: Accompaniment	Shredder Use: Salad
Carrot	Quad® blade or mini Use: Vegetable soup	0-5	Shredder Use: Salad
Cauliflower (cooked)	Quad® blade or mini Use: Cauliflower soup		
Celery	Quad® blade or mini Use: Vegetable soup	Thin 1-2 med 2-3 Use: Salad	
Eggplant	Quad® blade or mini Use: Accompaniment, soups	2-5 Use: Grilled eggplant	
Herbs	Quad® blade or mini Use: Seasoning or pesto		
Leeks	Quad® blade or mini Use: Cooked for soups	2-5 Use: Vegetable soup	
Onion	Quad® blade or mini Use: Soups, sauces	0-5 Use: Salad	
Potatoes		0.3-6 Use: Potato au Gratin	Shredder Use: hash browns
Potatoes (cooked)	Quad® blade or mini Use: Mash potato		
Tomatoes	Quad® blade or mini Use: Salsa	2-5 Use: sandwich filling, caprese salad, tomato relish	

FOOD	BLADE TYPE	ADJUSTABLE SLICING DISC THICKNESS	RECOMMENDED DISC TYPE
Apple / Pear	Quad® blade or mini Use: Apple sauce	2-5 Use: Apple pie	
Apple / Pear (cooked)	Quad® blade or mini Use: Baby food	4-6 Use: Fruit salad	
Dried Fruit	Quad® blade Use: Fruit salad, dessert sauce		
Batters	Quad® blade Use: Cakes, pancake, waffle batter		
Breadcrumbs	Quad® blade Use: Coatings, breadcrumb stuffing		
Cheese		2-5 Use: Garnish, sandwich fillings	Shredder - coarse or fine Use: Grated cheese for pizza
Chocolate	Quad® blade Use: Chocolate ganache		Shredder - Coarse or fine Use: Dessert decoration
Doughs	Dough blade Use: Bread, pizza		
Pastry	Quad® blade		
Eggs (whole or yolks)	Quad® blade or mini Use: Mayonnaise		
Meat (raw)	Quad® blade Use: Meatloaf, burgers, meatballs		
Meat (cooked)	Quad® blade Use: Sandwich fillings, pate, baby food		
Meat (deli)		1-6 Use: Sandwiches, antipasto, pizza toppings	



Care & Cleaning

Remove the power cord from the power outlet after use for safety reasons.

Processing bowl and lid

Due to the interlock components, we do not recommend immersing the bowl in water for long periods.

To keep your bowl and lid clean, and to avoid food drying on, follow these steps as soon as possible after use:

- Rinse most of the ingredients off the bowl and lid.
- Hand wash in warm, soapy water using a mild liquid detergent and non-abrasive sponge.

Motor base

To clean the motor base, wipe with a soft, damp cloth then dry thoroughly. Wipe any excess food particles from the power cord.

Cleaning agents

Do not use abrasive scouring pads or cleansers on either the motor base or the jug, as they may scratch the surface. Use only warm soap water with a soft cloth.

Dishwasher

The processing bowl and lid may occasionally be washed in the dishwasher (top shelf only), however washing in the dishwasher is not recommended on a regular basis, as prolonged exposure to harsh detergents, hot water and pressure will damage and shorten the life of the plastic and the interlock components.

Stubborn food stains and odors

Strong smelling foods such as garlic, fish and some vegetables such as carrots may leave an odor or stain the bowl or lid.

To remove, pour warm soapy water and fill to the MAX LIQUID mark. Set aside to soak for 5 minutes, without immersing the whole bowl. Then wash with a mild detergent and warm water, rise well and dry thoroughly. Store the bowl with the lid off.

Storage

Place the large food pusher (with medium and small pushers inserted) into the feed chute for storage.

Store your food processor upright, with the bowl and lid resting in position, but not locked. Locking the bowl and lid can put unnecessary strain on the safety interlock.

All accessories should be kept in the storage container and out of the reach of children to avoid accidental cuts. It is not recommended to store the discs in a drawer with other utensils.

Do not place anything else on top of your food processor during storage.



Troubleshooting

PROBLEM	EASY SOLUTION
Food is unevenly processed	<ul style="list-style-type: none">• Ingredients should be cut evenly into 2.5cm pieces before processing.• Ingredients should be processed in batches to avoid overloading.
Slices are slanted or uneven	<ul style="list-style-type: none">• Place evenly cut food into the feed chute.• Apply even pressure on the pusher.
Food falls over in the feed chute	<ul style="list-style-type: none">• The large feed chute must be packed full for best results. If processing smaller quantities, place items to the far left in the feed chute, or use the small or medium feed chute, depending on the food size.
Some food remains on top of the disc after processing	<ul style="list-style-type: none">• It is normal for small pieces to remain after processing.
Motor slows down when kneading dough	<ul style="list-style-type: none">• Amount of dough may exceed maximum capacity. Remove half and process in two batches.• Dough may be too wet (see next page). If motor speeds up, continue processing. If not, add more flour, 1 tablespoon at a time until the motor speeds up. Process until dough cleans the side of the processing bowl.
Dough doesn't clean inside of the processing bowl	<ul style="list-style-type: none">• Amount of dough may exceed food processor maximum capacity. Remove half and process in two batches.• Dough may be too dry.
Dough nub forms on top of dough blade and dough does not become uniformly kneaded	<ul style="list-style-type: none">• Stop machine, carefully remove dough, divide it into 3 pieces and redistribute them evenly in the processing bowl.
Dough feels tough after kneading	<ul style="list-style-type: none">• Divide dough into 2 or 3 pieces and redistribute evenly in processing bowl. Process 10 seconds or until uniformly soft and pliable.
Dough is too dry	<ul style="list-style-type: none">• While machine is running, add water through the small feed chute, 1 tablespoon at a time until dough cleans the inside of the processing bowl.
Dough is too wet	<ul style="list-style-type: none">• While machine is running, add flour through the small feed chute, 1 tablespoon at a time until dough cleans the inside of the processing bowl.

PROBLEM

EASY SOLUTION

The motor does not start

- There is a safety interlock switch to prevent the motor from starting if it is not properly assembled. Make sure the processing bowl and lid are securely locked into position.
 - If you are slicing or shredding and the above solution does not work, make sure that the food contents in the feed chute are cut below the maximum fill line so that the activation rod can engage the motor.
 - Make sure the large food pusher is inserted in the feed chute low enough to engage safety interlock switch.
 - If the motor still will not start, check the power cord and power outlet.
-

The food processor shuts off during operation

- The lid may have become unlocked; check to make sure it is securely in position.
 - If the motor overloads, all buttons will flash in unison. Unplug at the wall, and allow the food processor to cool for 20-30 minutes before resuming.
-

The motor slowed down during operation

- This is normal as some heavier loads (e.g. slicing/shredding cheese) may require the motor to work harder. Reposition the food in the feed chute and continue processing.
 - The maximum load capacity may have been exceeded. Remove some of the ingredients and continue processing.
-

The food processor vibrates/moves during processing

- Make sure the rubber feet at the bottom of the unit are clean and dry. Also make sure that the maximum load capacity is not being exceeded.
 - This is normal as some heavier loads may require the motor to work harder.
-



Recipes

Homemade Mayonnaise

🕒 Prep 5 minutes

🥄 Makes 1½ cups

3 egg yolks
3 teaspoons Dijon mustard
1½ tablespoons lemon juice or white wine vinegar
1½ cups (375ml) grapeseed or light olive oil
Salt, to taste

1. Assemble food processing with spindle and Quad® blade. Place yolks, mustard and lemon juice, or vinegar, into bowl and secure lid. Process for 20 seconds or until combined.
2. While food processor is running, remove small food pusher and gradually add oil in a slow, steady stream and process until mixture thickened and combined. This will take approximately 2½ minutes. Season to taste with salt.

Variation

Garlic Aioli

Add 2 cloves of garlic, with the egg yolks.
Use olive oil instead of grapeseed oil.

Chipotle Chile Mayonnaise

Add 1 chipotle chili in adobo sauce with the egg yolk.

Roasted Red Capsicum Mayonnaise

Add 1 roasted red capsicum, peeled, seeds removed, roughly chopped and 1 clove garlic with the egg yolks.

Lime and Wasabi Mayonnaise

Use lime juice instead of lemon and add 1 teaspoon wasabi paste.

Caesar Dressing

Add 4 anchovies, 1 clove garlic and 1 tablespoon Worcestershire sauce with the egg yolk. Increase lemon juice to ¼ cup.

Parsley, Chive & Lemon Pesto

🕒 Prep 5 minutes

🥄 Makes 1 cup

2 cups fresh flat-leaf parsley
¾ cup coarsely chopped fresh chives
½ cup (60g) finely grated parmesan
½ cup (50g) slivered almonds, toasted
1 clove garlic
1 teaspoon lemon juice
½ cup (125 ml) olive oil
1 teaspoon finely grated lemon rind
Salt and freshly ground black pepper, to taste

1. Assemble food processor with mini bowl and mini blade. Place all ingredients into bowl, in the order listed, and secure lid. Process for 50 seconds or until almost smooth, scraping down sides of processor bowl if necessary. Season with salt and pepper to taste.
2. Transfer to an airtight container and place in the fridge until ready to use.

To store

Pesto will keep in an airtight container in the fridge for a few days. To prevent excess browning, pour a little extra oil over the top before storing.

Roasted Red Capsicum, Pine Nut & Feta Dip

🕒 Prep 20 minutes / Cook 10 minutes

🍴 Makes 1½ cups

2 (about 550g) large red capsicums
Olive oil spray
¾ cup (115g) pine nuts, toasted
¼ cup chopped fresh flat-leaf parsley
2 tablespoons chopped fresh coriander leaves
1 clove garlic
2 tablespoons lemon juice
1 tablespoon olive oil
½ teaspoon ground coriander
½ teaspoon smoked hot paprika
80g feta, crumbled
Salt and freshly ground black pepper, to taste

1. Preheat oven to 220°C no fan (180°C fan-forced). Pierce capsicums a few times with a fork, spray with oil and place on a large baking tray lined with non-stick baking paper.
2. Roast for 40 minutes, turning halfway, or until skin is blistered and blackened. Seal inside a large re-sealable bag and set aside for 10 minutes or until cool enough to handle. Peel and discard skin. Carefully open capsicums (steam will escape) to remove and discard seeds and membranes.
3. Assemble food processor with spindle and Quad® blade. Place capsicum flesh, pine nuts, parsley, coriander, garlic, lemon juice, oil, ground coriander and smoked paprika into bowl and secure lid. Process for 20 seconds or until just combined and still a little chunky. Season with salt and pepper. Transfer to a serving bowl. Stir through feta. Cover and refrigerate for 1 hour for flavours to develop.

Leek & Potato Soup

🕒 Prep 15 minutes / Cook 35 minutes

🍴 Serves 4

2 leeks, white part only, trimmed
2 tablespoons olive oil
40g butter, chopped
750g potatoes, peeled, roughly chopped
4 cups (1L) chicken stock
Salt and white pepper, to taste

1. Assemble food processor with spindle and variable slicer set to setting 3–4 and secure lid. Place leeks one by one into small feed chute, white side down. Using food pusher thinly slice leeks.
2. Heat oil and butter in a large, heavy based saucepan over medium heat. Add leeks and cook, stirring occasionally, for 3–4 minutes until softened. Add potatoes and stock. Cover, bring to a boil then reduce heat to moderately low and simmer, stirring occasionally, for 25 minutes or until potatoes are soft. Allow the soup to cool.
3. Assemble food processor with spindle and Quad® blade. Transfer half the soup into the processor, secure lid, and process until smooth. Repeat with the remaining soup.
4. Return pureed soup to saucepan. Heat over medium heat until hot. Season to taste with salt and white pepper. Serve with our PARSLEY, CHIVE & LEMON PESTO recipe, drizzled over the top.



TIPS

If soup becomes too thick when cooking or processing add a little extra stock or water.

Chargrilled Chipotle Prawn Cakes with Lime & Avocado Aioli

🕒 Prep 20 minutes / Cook 10 minutes

🍴 Serves 4

2 gloves garlic
1 green onion, roughly chopped
1½ tablespoons chopped fresh coriander leaves
2 chipotle chillies in adobo sauce
1 tablespoon of adobo sauce
3 teaspoons lime juice
2 teaspoons finely grated lime rind
1kg uncooked king prawns, peeled, deveined
½ cup (40g) panko breadcrumbs
Salt and freshly ground black pepper, to taste
Cooking oil spray, to grease
Lime wedges, to serve

Lime & Avocado Aioli Ingredients

1 medium avocado, peeled, stone removed,
roughly chopped
¼ cup (60g) of our homemade mayonnaise recipe
(see page 21)
2 tablespoons lime juice
2 cloves garlic
Salt and freshly ground black pepper, to serve
Lime wedges, to serve

1. To make prawn cakes, assemble food processor with spindle and Quad® blade. Place garlic, green onion, coriander, chillies, adobo sauce, lime juice and lime rind into bowl and secure lid. Process for 15-20 seconds or until finely chopped. Add prawns and breadcrumbs and secure lid. Process for 10-15 seconds or until minced and combined.
2. Using damp hands form tablespoons mixture into patties. Place onto a tray lined with non-stick baking paper and place in the fridge for 30 minutes.
3. To make aioli, assemble clean and dried food processor bowl, spindle and Quad® blade. Place avocado, mayonnaise, lime juice and garlic into bowl and secure lid. Process for 30 seconds or until combined, scraping down sides of bowl halfway. Transfer to a serving bowl, cover and place in the fridge until ready to serve.
4. Preheat barbecue or chargrill pan on medium heat. Spray prawn cakes with oil. Cook for 2-3 minutes each side or until cooked through. Serve with aioli and lime wedges.

Carrot Falafel with Radish Tzatziki

🕒 Prep 25 minutes / Cook 10 minutes

🍴 Serves 4

2 medium (180g) carrots, peeled
3 slices day old white bread, crusts removed, quartered
1/3 cup sesame seeds
400g can chickpeas, rinsed, drained
1 red onion, quartered
2 cloves garlic
1 egg, lightly beaten
2 tablespoons tahini
2 1/2 tablespoons plain flour
2 teaspoons ground cumin
1 teaspoon ground coriander
1/2 teaspoon baking powder
1/4 teaspoon sweet paprika
Salt and pepper, to taste
Vegetable oil, for shallow frying
Lemon wedges, to serve
Mixed leaf salad, to serve

Radish Tzatziki Ingredients

5 radishes (170g), trimmed, roughly chopped
1/3 cup fresh mint leaves
1 clove garlic
3/4 cup (200g) plain full fat Greek yogurt
2 teaspoons fresh lemon juice
Salt and pepper, to taste

1. To make carrot falafel, assemble food processor with spindle and coarse shredder and secure lid. Place carrots into the small feed chute. Process carrots, pushing down with small food pusher until grated. Transfer carrot to a bowl and squeeze out any excess liquid.
2. Remove shredding disc, dry processing bowl completely and assemble processor with spindle and Quad® blade. Place bread into processing bowl, secure lid and process for 20 seconds to make bread crumbs. Set aside in a bowl. Stir in sesame seeds. Add onion and garlic to food processor bowl and secure lid. Process 10-20 seconds or until finely chopped.
3. Add carrots, chickpeas, egg, tahini, flour, cumin, coriander, baking powder, half the bread crumbs and paprika to processing bowl. Season with salt and pepper and secure lid. Process for 10-15 seconds or until just combined. Texture should be slightly chunky, stop processing before it forms a puree. Transfer to a bowl.
4. Form level tablespoons of mixture into balls. Roll in remaining breadcrumb mixture then transfer to a tray lined with non-stick baking paper. Cover and refrigerate for 1 hour or until firm.
5. To make tzatziki, assemble clean and dried food processor bowl, spindle and Quad® blade. Place radishes, mint and garlic into food processor and secure lid. Process for 15 seconds, scraping down sides of bowl if necessary or until finely chopped. Add yogurt and lemon juice. Pulse until just combined. Season with salt and pepper. Transfer to a serving bowl.
6. Pour enough oil into a large, deep frying pan until 5cm deep. Shallow-fry falafel in batches, turning until golden all over, then drain on paper towels. Serve with radish tzatziki, lemon wedges and salad.

Moroccan Style Spiced Meatball & Egg Tagine

🕒 Prep 15 minutes / Cook 20 minutes

🍴 Serves 4

500g chuck steak trimmed, cut into 2cm pieces
1 slice day old bread, crust removed, torn into small pieces
2 tablespoons chopped fresh flat-leaf parsley
2 tablespoons chopped fresh mint leaves, plus 1 tablespoon extra to garnish
2 teaspoons ground cumin
1½ teaspoons smoked paprika
1 teaspoon ground cinnamon
¼ teaspoon ground allspice
5 eggs
2 tablespoons oil
1 onion, roughly chopped
2 cloves garlic, crushed
800g can diced tomatoes
Toasted Turkish bread, to serve

1. Preheat oven to 200°C no fan (180°C fan-forced).
2. Assemble the food processor with bowl, spindle and Quad® blade. Add beef into bowl and secure lid. Process for 10 seconds or until minced. Transfer to a bowl.
3. Place bread, parsley, mint, 1 teaspoon cumin, ½ teaspoon paprika, ½ teaspoon cinnamon and allspice into processing bowl and secure lid. Process for 10 seconds or finely chopped. Return beef mince to processing bowl and add 1 egg. Pulse until mixture is combined. Form tablespoons mixture into meatballs.
4. Add 1 tablespoon oil in a large, deep ovenproof frying or cast iron skillet over medium high heat. Cook meatballs, in batches, for 8 minutes or until browned and almost cooked through, add more oil to the pan if required. Transfer to a large plate.
5. Assemble the cleaned and dried food processor with spindle and Quad® blade. Place onion into bowl and secure lid. Process for 10–15 seconds or until finely chopped.
6. Heat remaining oil in the frying pan over medium heat. Add onion and cook, stirring for 8 minutes or until golden brown. Add garlic, remaining cumin, remaining paprika and remaining cinnamon. Cook, stirring, for 30 seconds or until fragrant. Add tomatoes. Bring to a simmer over medium heat. Reduce heat to low and simmer for 8 minutes or until thickened slightly. Add meatballs. Stir until coated.
7. Make four wells in the tomato mixture. Carefully crack remaining eggs into each well. Bake for 10–12 minutes or until eggs whites are just set and yolks are still a little runny. Garnish with extra mint and serve with toasted Turkish bread.



TIPS

Swap beef for boneless lamb shoulder or lamb leg. For a little extra spicy kick add 1 finely chopped red chilli with the garlic and spices.

Malaysian Chicken Curry

🕒 Prep 20 minutes / Cook 1 hour 20 minutes

🍽️ Serves 4

1½ tablespoons rice bran or vegetable oil
8 (1.2kg) chicken drumsticks or thigh cutlets
1 teaspoon ground turmeric
2 cups (500ml) chicken stock
8 (380g) baby chat or baby red potatoes, peeled, halved
2 tomatoes (about 225g), coarsely chopped
2 cinnamon sticks
1 star anise
½ cup (125ml) coconut cream
2½ tablespoons finely grated palm sugar
4 teaspoons fish sauce
Fresh coriander leaves, to garnish
Steamed jasmine rice, to serve

Curry Paste Ingredients

6 long dried red chillies
4cm piece ginger, peeled, thinly sliced
1 lemongrass stalk, white part only, thinly sliced
5 (about 200g) red or golden shallots, chopped
5 cloves garlic
2 coriander roots, scrubbed and washed
1 tablespoon water
2 teaspoons roasted shrimp paste
3 teaspoons ground coriander
1½ teaspoons ground cumin
1 teaspoon ground fenugreek
1 teaspoon ground fennel
½ teaspoon salt
2 tablespoons rice bran or vegetable oil

1. To make curry paste: place chillies into a heatproof bowl or jug and cover with boiling water. Set aside for 20 minutes or until softened, then drain and coarsely chop. Assemble food processor with mini bowl and mini blade. Add soaked chillies, ginger, lemongrass, shallot, garlic, coriander roots, water, shrimp paste, spices and salt to mini bowl and secure lid. Process for 1 minute or until finely chopped, scraping sides of bowl down occasionally. Add oil and secure lid. Process for 20 seconds or until a paste forms.
2. Heat oil in a large heavy based saucepan over medium-high heat. Cook chicken, in batches, turning occasionally, for 5 minutes or until browned all over. Transfer to a bowl. Reduce heat to medium. Add curry paste and turmeric and cook, stirring occasionally, for 5 minutes or until fragrant. Stir in stock. Add chicken, potatoes, tomatoes, cinnamon and star anise. Bring to the boil then reduce heat to medium low and simmer, covered, for 40 minutes or until chicken is cooked and potatoes are tender.
3. Stir in coconut cream, palm sugar and fish sauce and simmer, uncovered, for 10 minutes or until slightly thickened. Remove and discard cinnamon and star anise. Transfer curry to a serving dish. Garnish with coriander and serve with rice.

Pizza Dough

⌚ Prep 5 minutes plus 30 minutes to rest

🍴 Makes enough for four 30cm thin crust pizzas or two 30cm thicker crust pizzas

3 cups (400g) bread flour

3 teaspoons instant dried yeast

3 teaspoons sugar

3 teaspoons salt

1 tablespoon olive oil

1 cup (250ml) warm water

1. Assemble food processor with spindle and dough blade. Place flour, yeast, sugar, salt and olive oil into bowl and secure lid. With the motor running, slowly add the water through the feed chute. Process until dough forms into a ball. Do not over process.
2. Carefully remove dough and knead on a lightly flour dusted surface to smooth. Place dough ball into a lightly oiled bowl, cover and rest in a warm place for 30 minutes or until dough has doubled in size. Turn dough out on a floured surface and punch down the dough to remove excess air then lightly knead.
3. For thin crust, divide dough into 4 x 170g dough balls, cover and set aside until required. For thicker crust, divide dough into 2 even dough balls, cover and set aside until required.

Margherita Pizza

⌚ Prep 10 minutes / Cook 15 minutes

🍴 Makes 1 pizza

170g pizza dough for thin crust (or one half of the dough for thicker crust)

¼ cup (60ml) pizza sauce

⅓ cup (40g) shredded mozzarella cheese

⅓ cup fresh basil leaves, torn plus extra basil leaves to garnish

6 cherry tomatoes, quartered

4 drained bocconcini cheese balls, sliced 1cm thick

1. Preheat oven to 220°C no fan (200°C fan-forced). Lightly flour one round 30cm diameter pizza tray.
2. Roll out dough onto a lightly floured surface to a 30cm diameter round. Place onto prepared tray and prick evenly with a fork.
3. Spread pizza sauce over pizza base, sprinkle evenly with mozzarella cheese, basil, cherry tomatoes and bocconcini. Bake for 12-15 minutes until base is crisp and topping is golden and melted. Garnish with extra basil.

Vietnamese Chicken Salad

(Goi Ga)

🕒 Prep 25 minutes / Cook 12 minutes

🍴 Serves 4

2 skinless chicken breast fillets
4 cups (1L) chicken stock
3 cardamon pods
2 star anise
2 cinnamon sticks
Freshly ground pepper, to taste
¼ medium green cabbage
200g snow peas, trimmed
2 medium carrots, halved crossways
2 Asian red shallots
1 cup (90g) bean sprouts
1 cup packed fresh mint leaves
1 cup packed fresh coriander leaves
⅔ cup (100g) roasted peanuts,
roughly chopped
½ cup fried shallots (see TIP), to garnish
1 fresh long red chili, thinly sliced, to garnish
(optional)

Dressing

2 fresh small red (birds eye) chillies, seeds removed
2 cloves garlic
3cm piece ginger, peeled, roughly chopped
¼ cup (60ml) fish sauce
½ cup (125ml) fresh lime juice
2 tablespoons sugar

1. To make dressing, assemble food processor with spindle and Quad® blade. Place ingredients into bowl and secure lid. Process for 15 seconds or until combined and sugar has dissolved. Transfer to a jug.
2. Place chicken in a saucepan, cover with stock, add cardamom, star anise and cinnamon. Season with pepper. Bring to a simmer over high heat. Reduce heat to low and simmer for 10 minutes or until chicken is just cooked through. Remove from heat and set aside in pan for 15 minutes to cool. Use a slotted spoon to transfer the chicken to a heatproof bowl. Cover with plastic wrap and place in fridge for 2 hours to chill. Discard stock and spices.
3. Assemble the cleaned and dried food processor with spindle and fine shredding disc and secure lid. Shred carrot, in batches, through small feed chute. Using coarse shredder, shred snow peas, in batches, through large feed chute. Transfer carrot mixture to a large bowl.
4. Assemble food processor with spindle and slicing disk (set to 2) and secure lid. Cut cabbage into wedges to fit large feed chute. Process cabbage in batches until shredded. Add to carrot mixture. Again with the slicing disk (set to 1), thinly slice shallots through the small or medium feed chute, depending on size. Add to cabbage mixture with the bean sprouts, mint, coriander and half the peanuts then toss to combine.
5. Finely shred the chicken (by hand) and add to cabbage mixture. Drizzle over dressing and toss to combine. Divide among serving bowls garnish with remaining peanuts, fried shallots and chilli.



TIPS

- Fried shallots can be found in the Asian aisle of your supermarket or Asian grocery stores.
- For a spicy dressing leave some of the seeds in the chillies.

Goat Cheese & Leek Tart

🕒 Prep 20 minutes / Cook 1 hour

🍴 Serves 6–8

2 leeks, white part only
80g butter, chopped
1 tablespoon olive oil
1 tablespoon chopped fresh thyme,
plus extra sprigs to garnish
Sea salt and freshly ground black pepper, to taste
80g goats cheese, crumbled
300ml cream
4 eggs

Shortcrust Pastry Ingredients

250g flour
135g chilled butter, chopped
1 egg
1–2 teaspoons ice cold water

1. To make pastry, assemble food processor with spindle and Quad® blade. Place flour and butter into bowl and secure lid. Process ingredients until mixture resembles a fine crumble. Add egg and water; process until mixture forms a ball. Do not over process. Add water gradually as you may not need it all.
2. Lightly knead dough by hand until smooth. Shape into a disc. Cover with plastic wrap and place in the fridge for 20 minutes to chill.
3. Preheat oven to 180°C no fan (160°C fan-forced). Lightly grease a 25cm x 3cm loose base round flan tin.
4. Assemble food processor with spindle and variable slicer (set to 3–4) and secure lid. Place leeks one by one into small feed chute, white side down. Using small food pusher, thinly slice leeks.
5. Heat butter and oil in a large frying pan over medium heat. Add leeks and cook, stirring, for 5–7 minutes or softened.
Add thyme and cook, stirring, for an additional minute. Season with salt and pepper and set aside.
6. Roll dough between two sheets of baking paper large enough to line tin. Line tin with pastry; trim any excess. Using a fork press several holes around the middle of the pastry. Cover pastry with non-stick baking paper and fill with baking beads, uncooked rice or dried beans. Bake in oven for 15 minutes. Remove paper, beads, rice or beans. Bake for an additional 5 minutes.
7. Spread leeks evenly over base of pastry. Sprinkle with goats cheese and top with extra sprigs of thyme. Whisk together cream, eggs, salt and pepper; pour over leek mixture. Bake for 30 minutes or until set. Allow to cool for 30 minutes before serving.

Choc Chip, Pecan & Oat Cookies

🕒 Prep 15 minutes / Cook 12 minutes

🍴 Makes 28

125g butter, softened, chopped
½ cup (110g) caster sugar
½ cup (110g) firmly packed brown sugar
1 egg
2 teaspoons vanilla extract
1⅓ cups (200g) self-raising flour
½ teaspoon salt
1 cup (190g) dark choc chips
½ cup (70g) pecan halves, roughly chopped
¼ cup (25g) rolled oats

1. Preheat oven to 180°C no fan (160°C fan-forced). Line 3 large baking trays with non-stick baking paper.
2. Assemble food processor with spindle and Quad® blade. Place butter, brown sugar, bakers sugar, egg and vanilla into bowl and secure lid. Process for 10 seconds or until mixture is smooth and combined. Add flour and salt to food processor bowl and secure lid. Pulse 8-10 times or until just combined. Add choc chips, nuts and rolled oats and secure lid. Pulse 5 times or until just combined.
3. Place heaped tablespoons of mixture, 3-4 cm apart, on prepared trays. Bake for 10-12 minutes or until golden. Set aside on trays for 5 minutes to cool slightly. Use a spatula to transfer to a wire rack to cool completely.

Dark Chocolate Ganache

🕒 Prep 5 minutes / Cook 2 minutes

🍴 Makes 3 cups (790g)

600g dark chocolate, roughly chopped
300ml pure cream

1. Assemble food processor with spindle and Quad® blade, ensuring bowl and attachments are completely dry. Place chocolate into bowl and secure lid. Process for 20-30 seconds or until very finely chopped.
2. Place cream into a saucepan. Bring just to a boil over medium heat. Add chocolate and stir 10 seconds or until chocolate is melted and mixture is smooth and glossy. Transfer to a bowl. Set aside to cool slightly.



TIPS

- Use ganache straight away as a chocolate sauce or use a filling for a tart by pouring into a cupcake paper and then chill in the fridge until set.
- To use as an icing for cakes or cupcakes set ganache aside at room temperature for about 2-3 hours or until a spreadable consistency.
- To use to make truffles, place ganache into an airtight container and place in the fridge until thickened and firm. Roll tablespoons of mixture into balls then roll in cocoa, chocolate sprinkles, chopped nuts or shredded coconut.

Gluten Free Orange, Almond & Pistachio Cake

🕒 Prep 15 minutes / Cook 1 hour

🍴 Serves 10

2 oranges (about 395g), washed, scrubbed
125g blanched almonds
125g pistachio kernels, plus extra 45g roughly chopped, to garnish
5 eggs
1¼ cups (275g) caster sugar
1 teaspoon gluten free baking powder
Icing sugar, to garnish
Crème Fraiche or full fat natural Greek yogurt, to serve

1. Using a fork prick the oranges all over a few times. Place into a microwave safe dish. Microwave on HIGH for 8 minutes, turning halfway through. Set aside to cool completely. Cut oranges in quarters; remove and discard seeds.
2. Preheat oven to 180°C no fan (160°C fan-forced). Grease and line the base and side of a round 22cm (base measurement) spring form pan with baking paper.
3. Assemble food processor with spindle and Quad® blade. Place almonds and pistachios into bowl and secure lid. Process for 50 seconds or until processed into meal. Transfer to a bowl. Add orange quarters (including skin) to food processor bowl. Process for 1 minute or until pureed, scraping sides of bowl down if necessary.
4. Using an electric mixer beat eggs and sugar until thickened. Use a large metal spoon to fold in orange pulp, pistachio meal and baking powder until combined. Spoon mixture into prepared pan. Bake for 50 min-1 hour or until skewer inserted in the centre comes out clean. (If top starts to overbrown, cover with foil). Set aside for 15 minutes to cool slightly. Remove from pan and transfer to a wire rack to cool completely.
5. Remove from pan. Dust with icing sugar and garnish with extra pistachios. Serve with crème fraiche or yogurt.

Little Lime & Passionfruit Cheesecakes

🕒 Prep 15 minutes / Cook 20 minutes

🍴 Makes 22

250g packet plain sweet biscuits, quartered
125g butter, melted
⅓ cup (150g) caster sugar
200 ml sour cream
3 eggs
3 teaspoons lime rind
1 tablespoon lime juice
2 x 250g packets cream cheese, chopped, softened at room temperature
¼ cup (60ml) passionfruit pulp (about 4 passionfruit)

1. Preheat oven to 160°C no fan (140°C fan-forced). Line 22 holes of two 12-hole, ⅓ cup (80ml) capacity muffin pans with paper cases.
2. Assemble food processor with spindle and Quad® blade. Place biscuits into bowl and secure lid. Process biscuits until mixture resembles fine breadcrumbs. Add butter. Process until combined. Divide mixture between paper cases and press down with the back of a spoon. Place in the fridge for 15 minutes to chill.
3. Meanwhile, assemble clean and dry processing bowl with spindle and Quad® blade. Place sugar, sour cream, eggs, lime rind and juice into bowl and secure lid. Process for 15 seconds or until smooth. Add cream cheese and passionfruit pulp. Process for 30 seconds or until just combined. Pour mixture into prepared cases. Bake for 20-25 minutes or until just set. Cool in oven with door ajar. Cover and refrigerate for 2 hours or until well chilled.

Breville Customer Service Centre

Australian Customers

Mail: PO Box 22
Botany NSW 2019
AUSTRALIA

Phone: 1300 139 798

Fax: (02) 9384 9601

Email: Customer Service:
askus@breville.com.au

Web: www.breville.com.au

New Zealand Customers

Mail: Private Bag 94411
Botany Manukau 2163
Auckland NEW ZEALAND

Phone: 0800 273 845

Fax: 0800 288 513

Email: Customer Service:
askus@breville.co.nz

Web: www.breville.co.nz

Breville[®]
Thought for food

Breville is a registered trademark of Breville Pty. Ltd. A.B.N. 98 000 092 928.
Copyright Breville Pty. Ltd. 2014.

Due to continued product improvement, the products illustrated/photographed
in this booklet may vary slightly from the actual product.